

4125- 4127 HOLLISTER BUSINESS PARK HOUSTON, TEXAS 77080

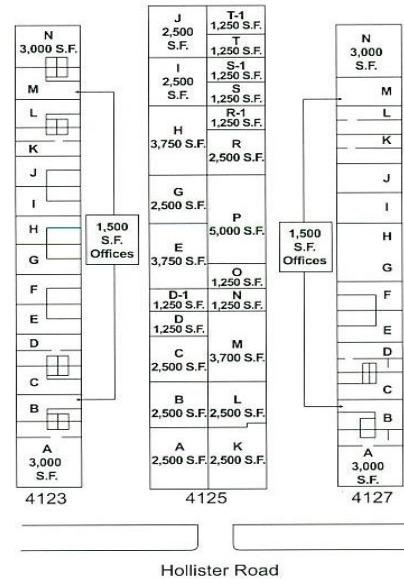

Conveniently located in Northwest Houston close to US 290 and approximately 15 miles from downtown.

Property Highlights

- Industrial/Warehouse For Lease
- Metal Building
- Eave Height: 14'
- Door Size: 12'X14'
- Phase I – 240 V,200 A 3-Phase Power
- Phase II – 208 V,200A 3-Phase Power
- 24 Hour Surveillance Camera System

**CONTACT US FOR MORE INFORMATION
OR TO SCHEDULE A PROPERTY TOUR**



HRES GROUP
BUSINESS PARKS
DEVELOPMENT * MANAGEMENT * LEASING

1771 Upland Drive, Suite 101
Houston, Texas 77043
(713) 984-0199
hres@hresgroup.com
hresgroup.com